



504 SR/SN Carrello multiuso



SR



SN

DATI TECNICI

- 3 ripiani da 770x448 mm
- Ripiani coperti da tappetini in ABS da 2 mm
- Bordi anticaduta da 37 mm su tutti e 3 i ripiani
- Maniglia in tubolare d'acciaio diametro 25 mm
- Fianchi predisposti per gli accessori laterali 516
- Due ruote pivotanti e due ruote fisse (Ø 100 mm) di cui una con freno
- Fornito smontato
- Portata massima: 200 Kg
- Struttura verniciata colore rosso RAL 3020 o nero RAL 9005



504 SR/SN Carrello multiuso

DISEGNO

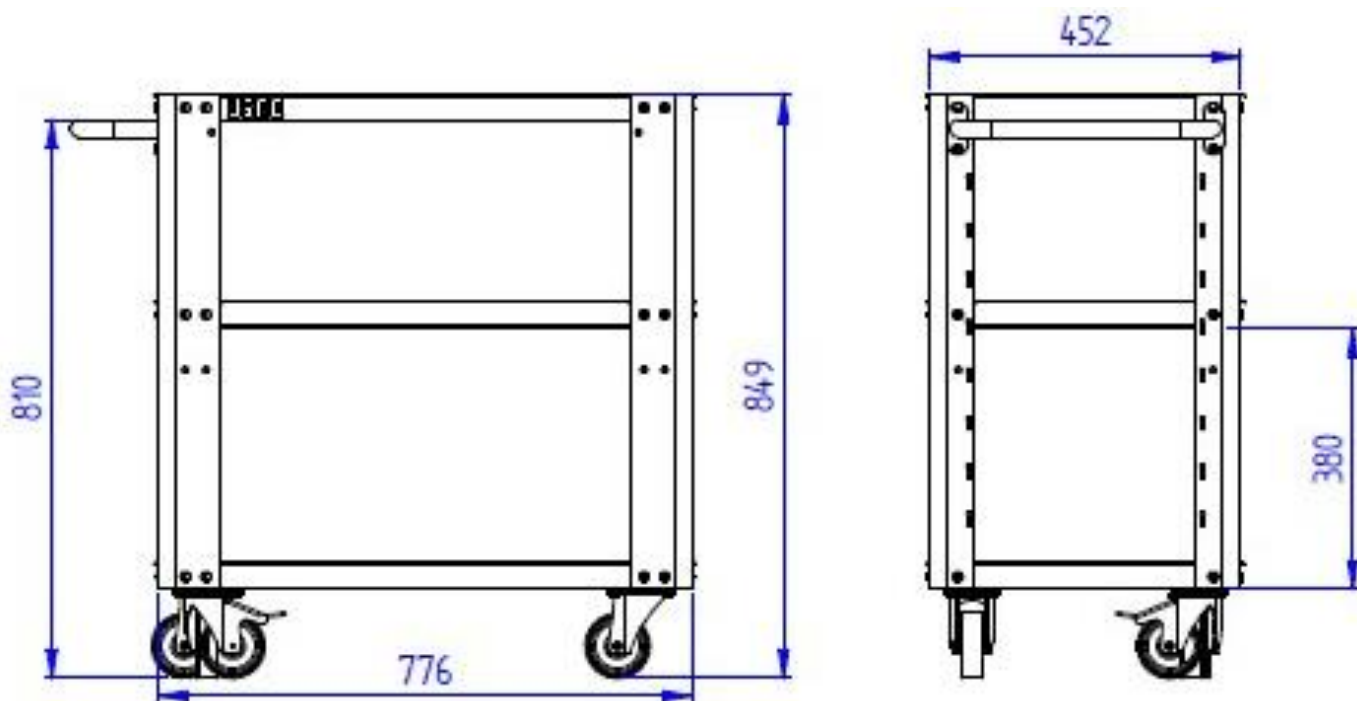

Peso: 25Kg

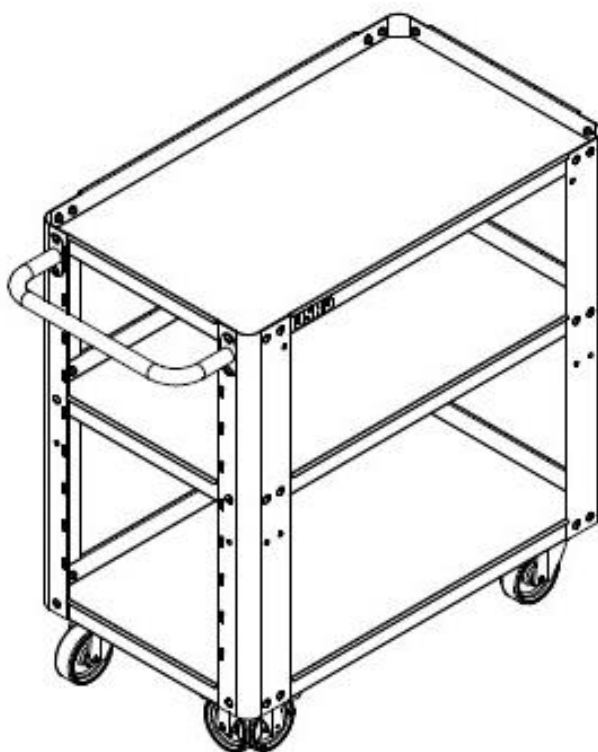

Dimensioni in mm



504 SR/SN Carrello multiuso

MATERIALI

Montanti laterali: lamiera in acciaio sp. 12 mm

Ripiani: lamiera in acciaio sp. 0,9 mm

Maniglia in tubolare: tubolare di diametro 25 mm sp 12 mm / piastre saldate di fissaggio sp. 2 mm

Tappetini: materiale plastico (ABS) sp. 2 mm

IMBALLO

- Scatola di cartone.



Stanley Black & Decker Italia Srl
Via Volta, 3 - 21020 Monvalle (VA)
Tel. +39 0332 790111 - Fax +39 0332 790330
info.mv@usag.it

USAG.IT
USAG-TOOLS.NET

UK Importer - USAG UK, 270 Bath Rd, Slough SL1 4DX, England